



HOME SERVICE PLANS

**Your home. Your budget.
Your peace of mind.
We've got it covered.**

888-243-HOME
ConstellationHome.com

 **Constellation Home.**

Formerly **BGE HOME**

Every time we enter a home, we leave it a better place to live.

That's the promise of Constellation Home. Our goal is to provide you with exceptional service and products so that your peace of mind remains intact, knowing we've got you covered. With a 100% satisfaction guarantee, you can relax and trust that no matter what in your home needs fixing, we have the knowledge and expertise to make it right. We take pride in the service we provide. So, you can count on Constellation Home to earn your trust time after time.

What makes us #1?

It's all about our technicians. From fine-tuning the most sophisticated, high-efficiency systems to simply fixing a leaky faucet, our hundreds of highly trained, certified professionals have seen it all. And it all starts well before we open our toolboxes. We respect you and your home. So we treat your home like it's ours.

OUR TECHNICIANS AVERAGE
**11 YEARS OF
EXPERIENCE**

**WE PLEDGE
TO LEAVE YOUR HOME
EVERY BIT AS CLEAN
AS WHEN WE ARRIVED**

**WE USE DROP CLOTHS
& WEAR PROTECTIVE
FOOTWEAR**

**ON TIME
OR EARLY 97% OF THE TIME**

**UP-FRONT
PRICING**
NO HIDDEN FEES

**PREMIER
IN-HOUSE TRAINING
& APPRENTICESHIP PROGRAM**

WHY CHOOSE ANYONE ELSE?



A simple way to keep your home running smoothly

Our homes are full of equipment that keeps us safe and comfortable. Inevitably, the time will come when it will need service or repairs to continue working properly. Don't let these repairs ruin your budget or cause you any stress.

We offer bundled service plans to protect entire systems in your home and single product plans to protect just one piece of equipment. So, no matter your need, there's a plan to protect and extend the life of your home equipment.

And, our team of reliable, certified technicians understands how all the systems in your house work together to keep you and your family safe. No matter what happens, your house can continue to feel like home.

†A \$50 per call, per item deductible will apply at time of service for Plumbing/Electrical Plans. ‡ Up to \$2,000 per contract year, unless otherwise stated.

\$0

FOR ALL COVERED
PARTS AND LABOR ‡

\$0

DEDUCTIBLE
OR COPAY†

**24/7
SERVICE**



**UNLIMITED
SERVICE CALLS**



**PRIORITY
SERVICE
SCHEDULING**

Bundled for greater protection

We offer Smart Service® bundled plans so you can protect entire rooms or systems within your home. Whether it's for the entire home or just the kitchen, there's a bundled plan that's right for you.

PLUS, WE OFFER EXCLUSIVE SMART SERVICE BENEFITS, INCLUDING:

- **10% OFF** any air conditioning/heating system replacement (up to \$500)
- **5% OFF** any water heater replacement (up to \$100)
- **10% OFF** any plumbing or electrical service call
- **10% OFF** any home improvement product (up to \$250)

OUR TOP-RATED SMART SERVICE PLAN



WHOLE HOUSE PLAN

Equipment Covered:

- Heating/Air Conditioning System
- Water Heater
- Refrigerator
- Range or Oven/Cooktop
- Dishwasher
- Washer
- Dryer

Exclusive Extras:

- Annual HVAC efficiency tune-up
- 15% off any non-covered HVAC service
- 15% off any non-covered Water Heater service
- 15% off any non-covered Appliance service

See pages 10 – 16 and 20 – 23 for coverage details.

OUR MOST POPULAR SMART SERVICE PLAN



HOME COMFORT PLAN

Equipment Covered:

- Heating/Air Conditioning System
- Water Heater

Exclusive Extras:

- Annual HVAC efficiency tune-up
- 15% off any non-covered HVAC service
- 15% off any non-covered Water Heater service

See pages 10 – 16 for coverage details.



SELECT SERVICE PLAN

Equipment Covered:

- Heating/Air Conditioning System
- Water Heater

Exclusive Extras:

- 20% off annual HVAC efficiency tune-up
- 15% off any non-covered HVAC service
- 15% off any non-covered Water Heater Service

See pages 10 – 16 for coverage details.



KITCHEN PLAN

Equipment Covered:

- Refrigerator
- Range or Oven/Cooktop
- Dishwasher

Exclusive Extras:

- 15% off any non-covered Appliance service

See pages 21 - 23 for coverage details.



LAUNDRY PLAN

Equipment Covered:

- Washer
- Dryer

Exclusive Extras:

- 15% off any non-covered Appliance service

See page 20 for coverage details.



PLUMBING & ELECTRICAL PLAN†

Equipment Covered:

- Plumbing System
- Electrical System

Exclusive Extras:

- 15% off any non-covered Plumbing service
 - 15% off any non-covered Electrical service
- †A \$50 per call, per item deductible will apply at time of service.

See page 17 for coverage details.



WATER/SEWER LINE PLAN

Equipment Covered:

- Water Line
- Sewer Line

Exclusive Extras:

- 15% off any non-covered Plumbing Line service

See page 19 for coverage details.



WELL PUMP PLAN

Equipment Covered:

- Well Pump
- Well Pressure Tank

Exclusive Extras:

- 15% off any non-covered Well Pump service

See pages 18 – 19 for coverage details.



WATER PRODUCTS PLAN

Equipment Covered:

- Water Neutralizer
- Water Softener
- Salt Brine Tank

Exclusive Extras:

- Annual maintenance check on Neutralizer
- 15% off any non-covered Water Product service

See pages 18 – 19 for coverage details.

Single product service plans

We offer peace of mind for every budget. Our single product service plans offer protection for an individual system or piece of equipment in your house.



HEATING, COOLING & INDOOR AIR QUALITY SERVICE PLANS

- Air Conditioners
- Heat Pumps
- Furnaces
- Boilers
- Aquatherms
- Mini-Splits (Ductless)
- Humidifiers (Whole House)
- Air Cleaners (Electronic)

See pages 10 - 13 for coverage details.



APPLIANCE SERVICE PLANS

- Refrigerators
- Freezers
- Ranges
- Ovens
- Cooktops
- Dishwashers
- Microwaves (Built-In Only)
- Washers
- Dryers

See pages 20 - 23 for coverage details.



PLUMBING SERVICE PLANS

- Water Heater
- In-Home Plumbing†
- Water Line
- Sewer Line
- Well Pump & Pressure Tank
- Neutralizers
- Water Softeners & Brine Tank

See pages 14-16 and 18-19 for coverage details.



ELECTRICAL SERVICE PLANS

- In-Home Electrical†

See page 17 for coverage details.



GENERATOR SERVICE PLAN

- Standby Backup Generator

See page 23 for coverage details.

†A \$50 per call, per item deductible will apply at time of service.

We make it easy to get covered and stay covered.



Big savings on typical repair costs

Protect your home with the service plan that's right for you. Just one unexpected repair could break your budget and cost more than what you'd pay for a whole year's worth of service plan coverage. With a service plan, you can protect your budget from costly repairs. **See how much you could save:**

CENTRAL A/C SYSTEM	HEATING SYSTEM	WATER HEATER (40 GAL.)
WITH SERVICE PLAN \$0	WITH SERVICE PLAN \$0	WITH SERVICE PLAN \$0
Without a Service Plan \$500	Without a Service Plan \$330	Without a Service Plan \$235
REFRIGERATOR	LIGHT FIXTURE REPAIR	KITCHEN SINK REPAIR
WITH SERVICE PLAN \$0	WITH SERVICE PLAN \$0	WITH SERVICE PLAN \$0
Without a Service Plan \$205	Without a Service Plan \$220	Without a Service Plan \$235



Convenient payment options

Constellation Home offers three hassle-free payment options to meet your needs:

- Autopay – checking account
- Autopay – credit card
- Direct billing on utility bill

Heating, Air Conditioning and Indoor Air Quality Equipment

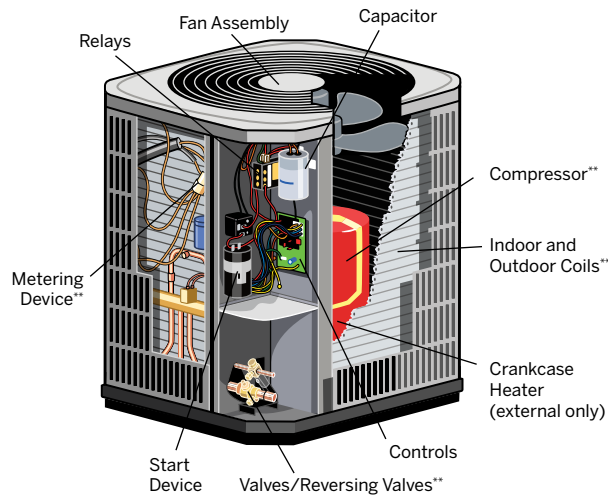

CENTRAL AIR CONDITIONING/HEAT PUMP

- Thermostat and exposed wiring*
- Accumulator, filter/driers and connecting refrigerant lines**
- Fan control
- Transformer
- Defrost controls and timers
- Thermal fuses

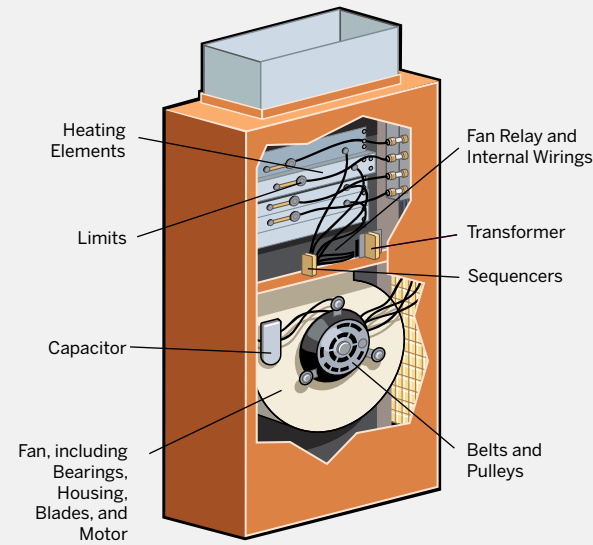

FORCED WARM AIR ELECTRIC HEAT SYSTEM

- Condensate pump
- Thermostat and exposed wiring*

FORCED WARM AIR GAS HEAT SYSTEM

- Thermostat and exposed wiring*
- Electronic ignition and circuit boards
- Condensate pump
- Draft hood
- Belts and pulleys
- Main burner

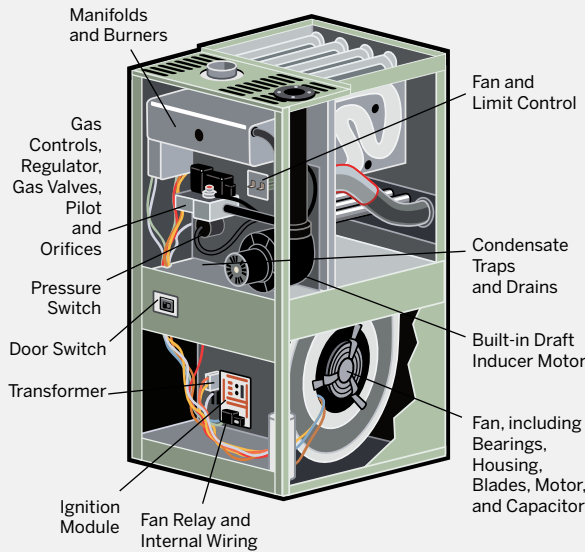

MINI-SPLIT SYSTEM (DUCTLESS)

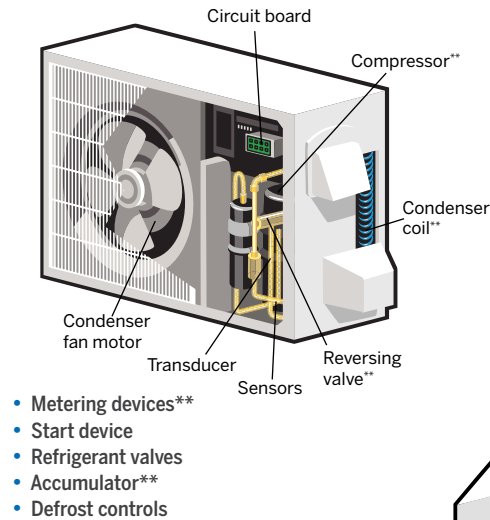

- Metering devices**
- Start device
- Refrigerant valves
- Accumulator**
- Defrost controls

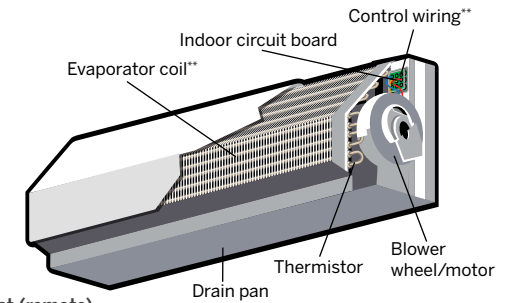

- Thermostat (remote)
- Air filters

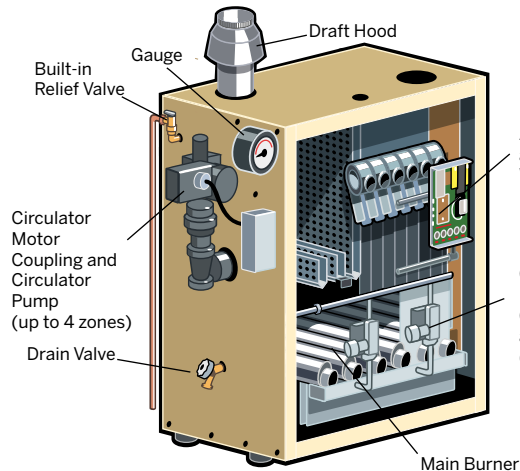

HOT WATER GAS HEAT SYSTEM

- Thermostat and exposed wiring*
- Aquastat and Internal Wiring
- Gas Controls, Regulator, Gas Valves, and Pilot (up to 2)

(Water leaks at the circulator flanges and piping are not covered.)

STEAM GAS HEAT SYSTEM

- Thermostat and exposed wiring*

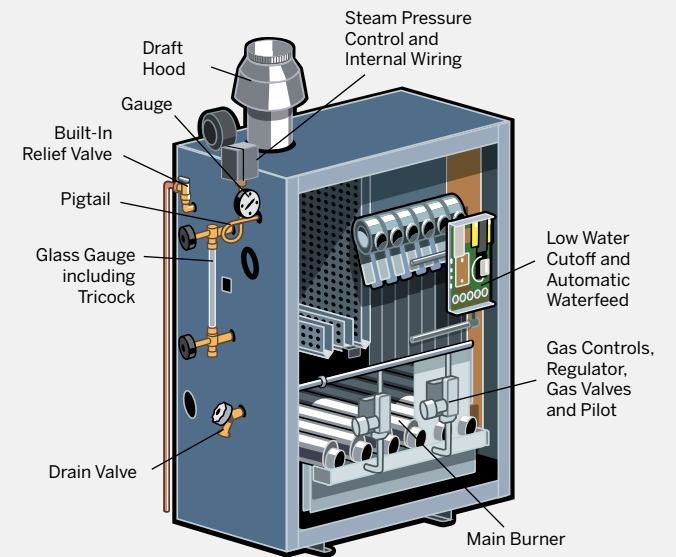

AQUATHERM

- Thermostat and exposed wiring*

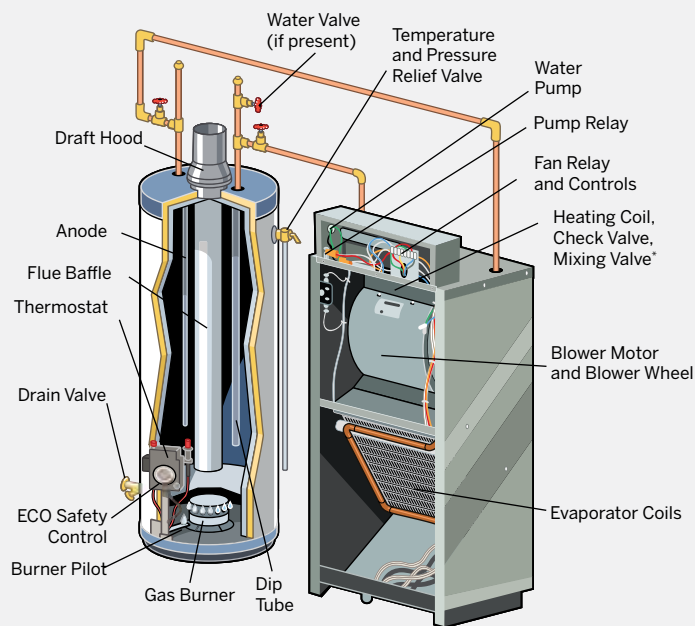

(Water Heater tank failure is not covered. Oil-fired and ground-source water heaters are not covered.)

WHOLE-HOUSE HUMIDIFIER

- All functional parts
- One pad change

ELECTRONIC AIR CLEANER

- All functional parts

Coverage is available only in conjunction with an air conditioning, heat pump or heating service plan. The pad change will be performed during the annual cooling and/or heating efficiency tune-up.

*Covered if installed by Constellation Home.
**Covered only under manufacturer's warranty.

Water Heater Coverage

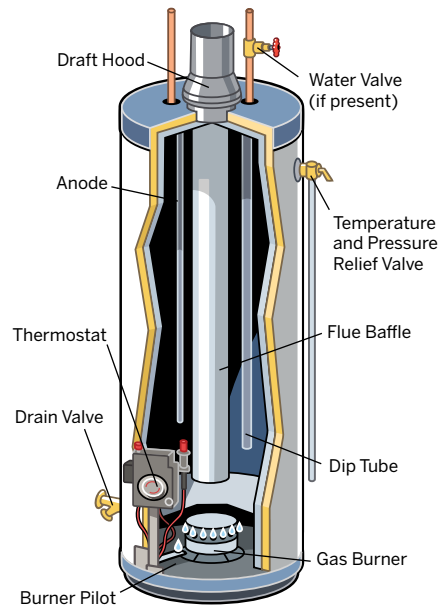

GAS WATER HEATER

ELECTRIC WATER HEATER

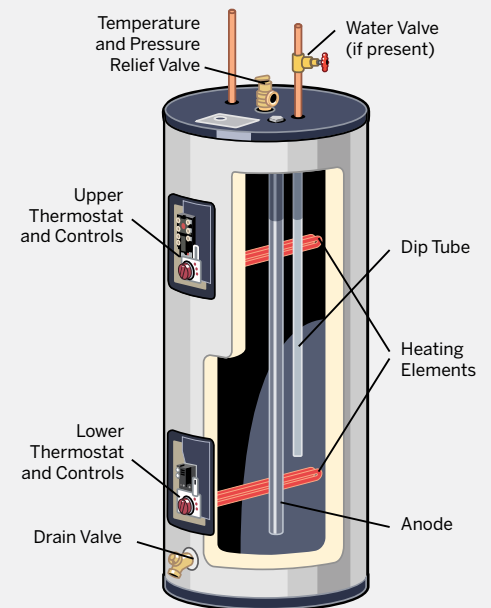

POWER VENTED GAS WATER HEATER

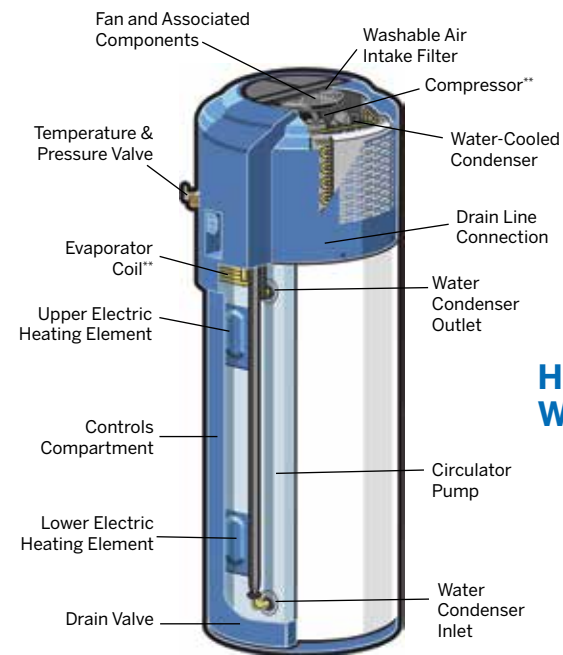
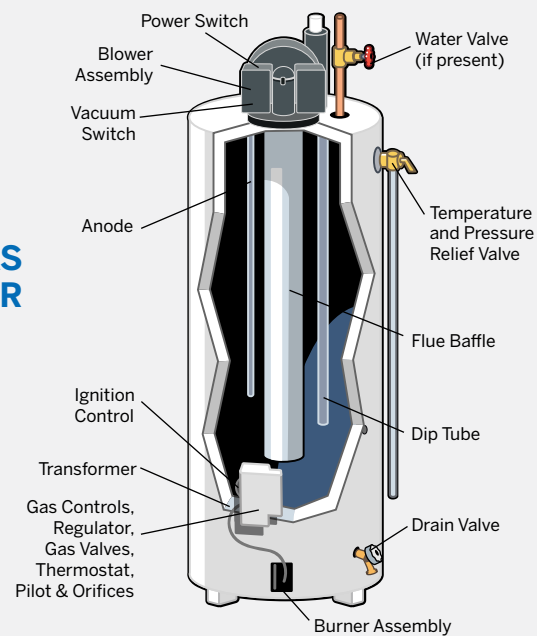

HEAT PUMP WATER HEATER

(Water Heater tank failure is not covered. Oil-fired and ground-source water heaters are not covered.)
 **Covered only under manufacturer's warranty.

Plumbing and Electrical Coverage

PLUMBING AND ELECTRICAL†

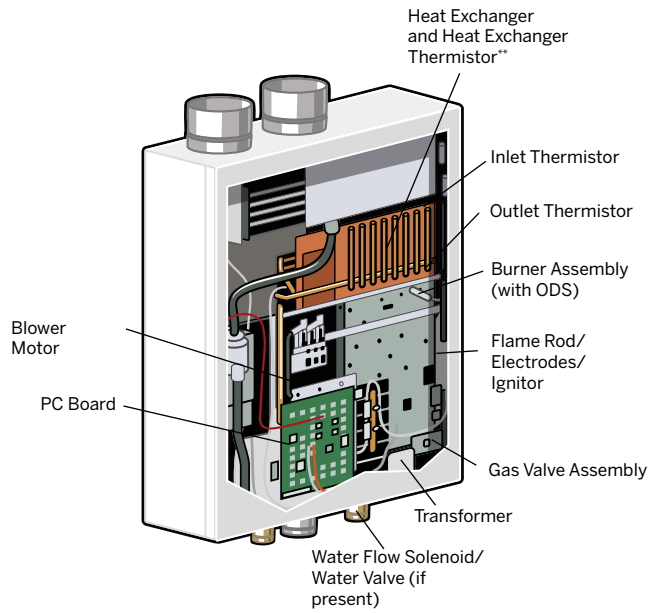

TANKLESS WATER HEATER

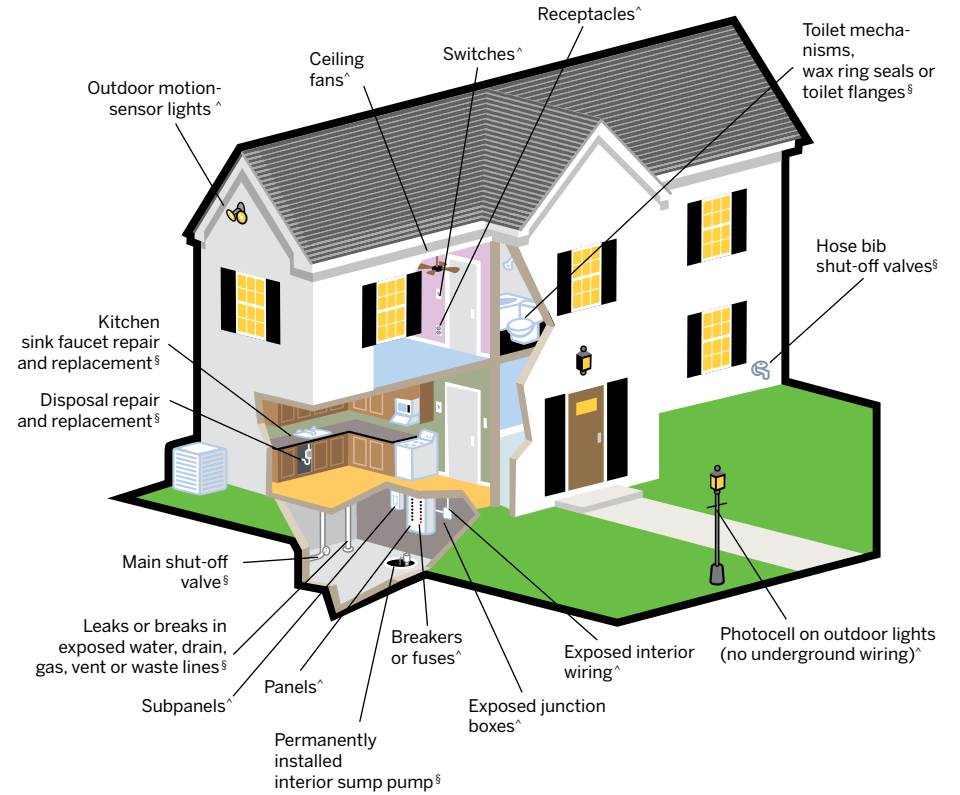

- Drain cleaning (inside house) §
- Angle stops (if present) §
- Light fixture repair and replacement ^
- Bathroom built-in exhaust fans ^
- GFI receptacles ^

MARATHON® ELECTRONIC WATER HEATER

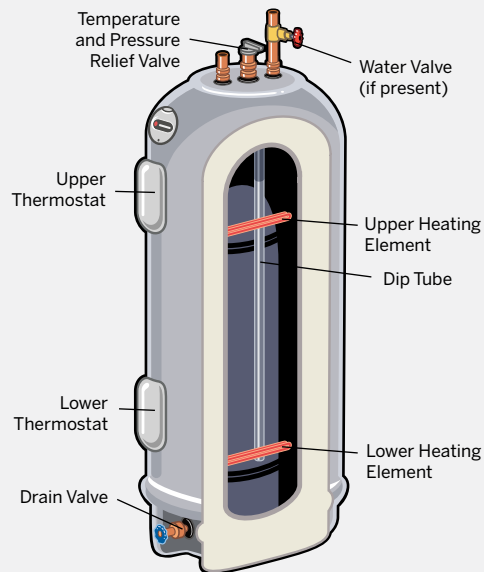

(Water Heater tank failure is not covered.)
 **Covered only under manufacturer's warranty.

†A \$50 per call, per item deductible will apply at time of service.

^ Included coverage with Electrical plans.

§ Included coverage with Plumbing plans.

Water Products Coverage

WELL PUMP

- Pump protector (covered under well pump plan)

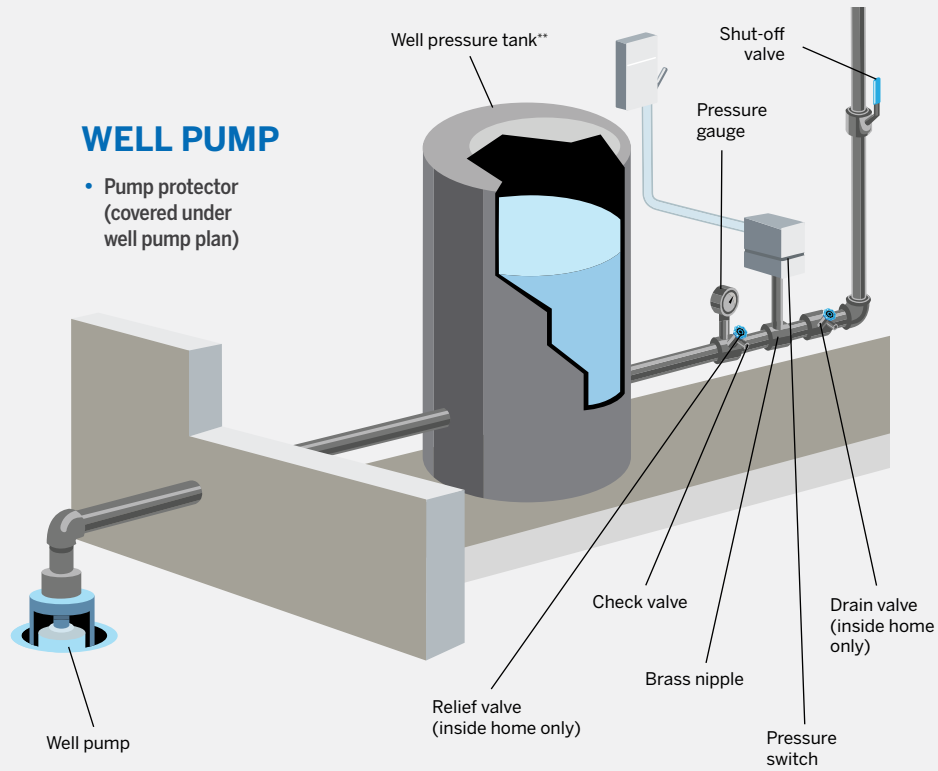

WATER & SEWER LINE

Repair coverage up to \$3,000 per Contract year (Water Line) or up to \$4,000 per Contract year (Sewer Line).

WATER SOFTENER

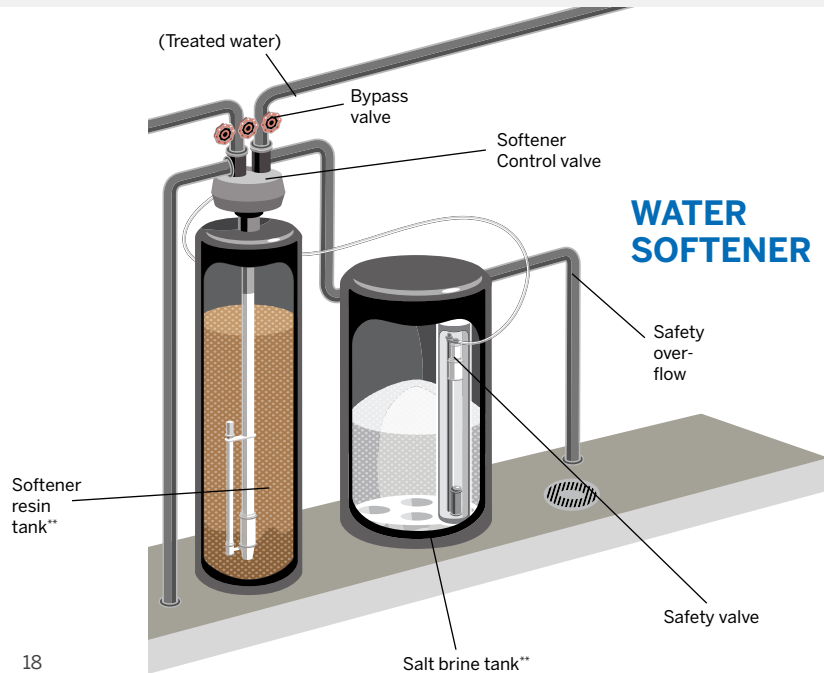

NEUTRALIZER SYSTEM

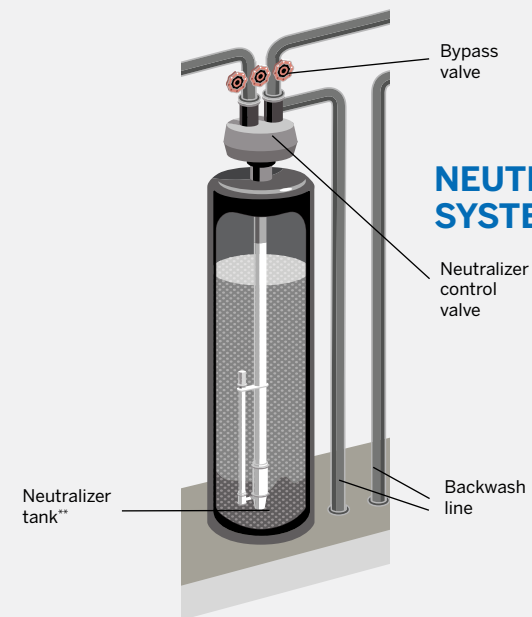

**Covered only under manufacturer's warranty.

Laundry Appliances

WASHER

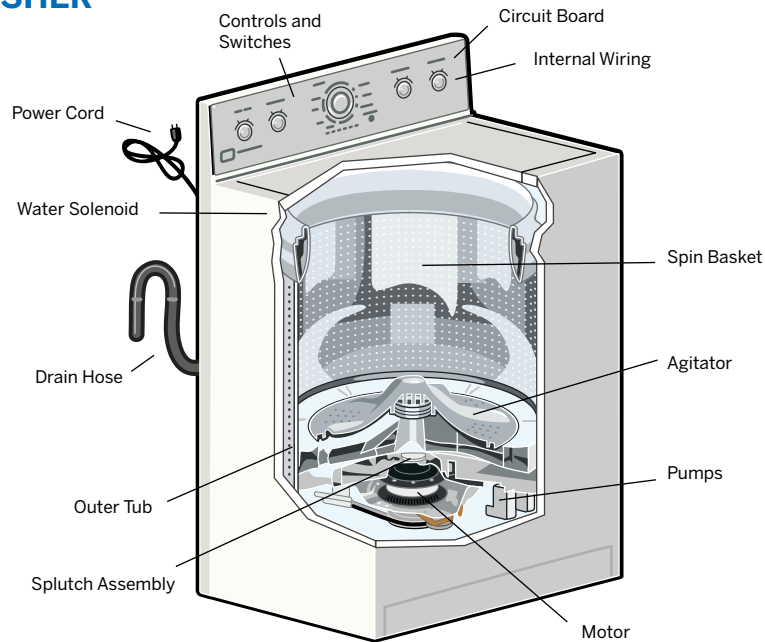

- Clutch, Brake, Transmission, Belts and Pulleys (typically found in older models)
- Valves (Mix and Suds Saver)
- Timer/Bleach Dispenser

Kitchen Appliances

ELECTRIC RANGE

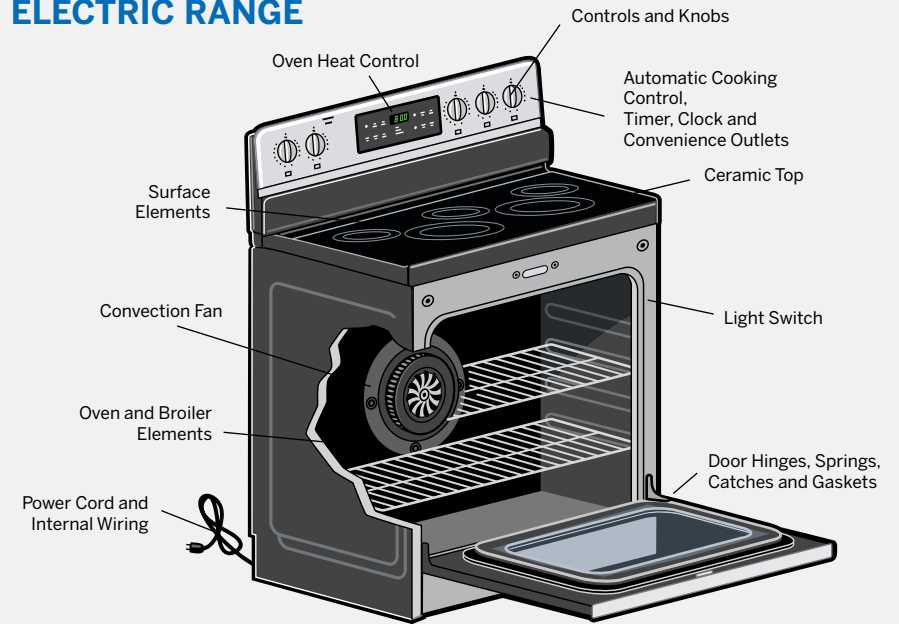

- Self-Cleaning Components

DRYER

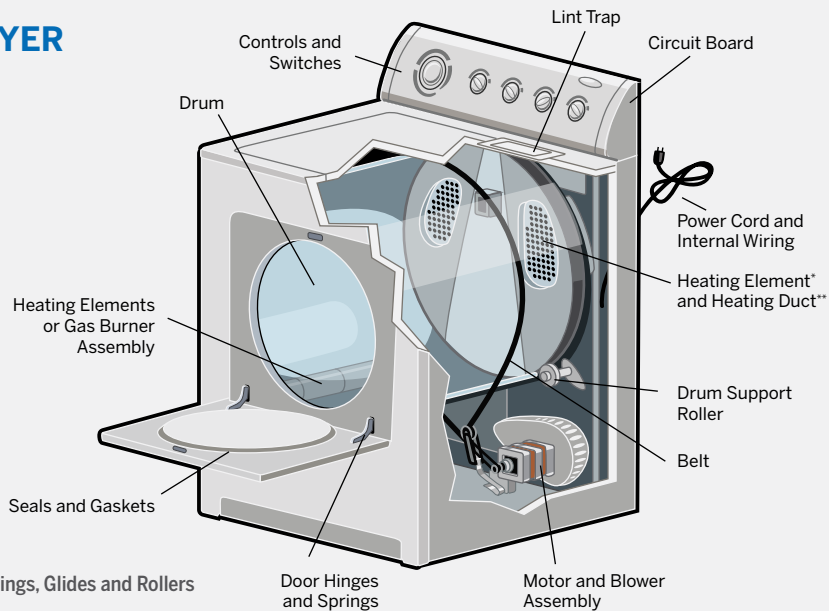

- Bearings, Glides and Rollers

**Covered only under manufacturer's warranty.

GAS RANGE

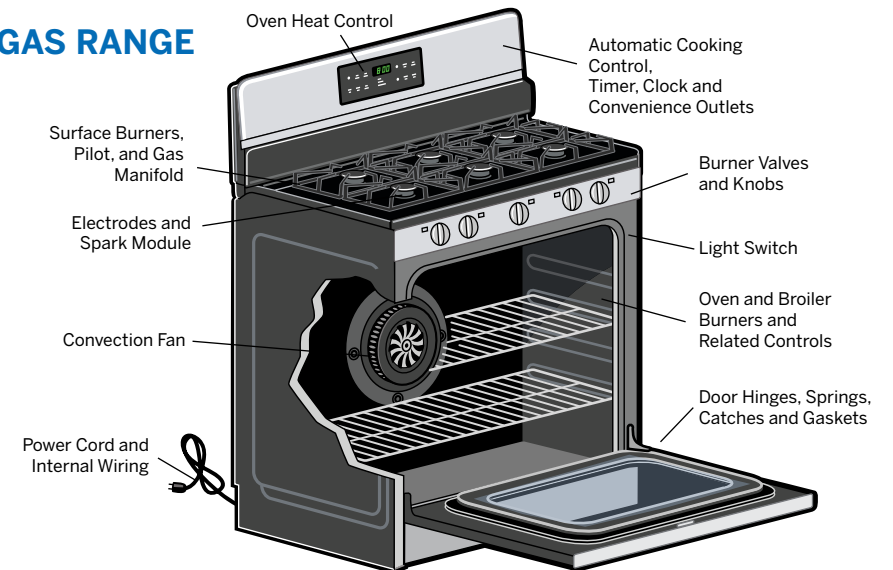

- Self-Cleaning Components
- Pressure Regulator

REFRIGERATOR/FREEZER

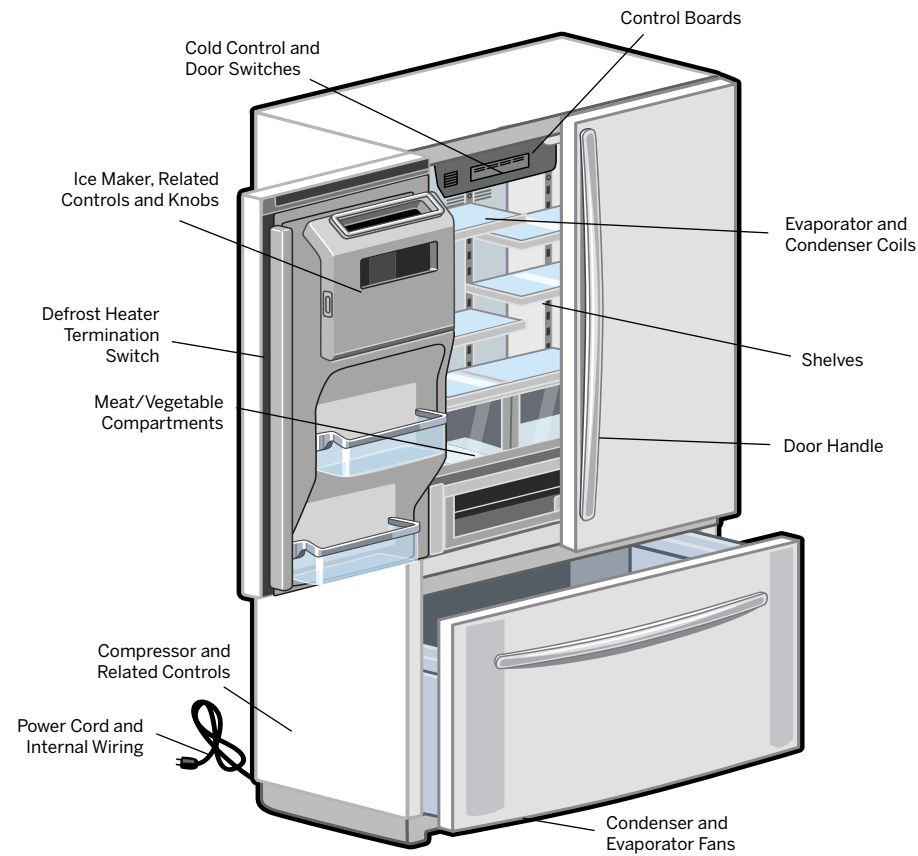

- Door Hinges, Springs, Gaskets and Latch
- Defrost Control
- Sealed System**

MICROWAVE

- Internal wiring panelboards
- Temperature controls
- Door handle and latches
- Mixer/stirrer blade
- Shelf and supports
- Probe
- Power cord
- Automatic timer
- All electronic parts

(For Microwave/Range Combination Unit coverage, review the individual coverage plans.)

DISHWASHER

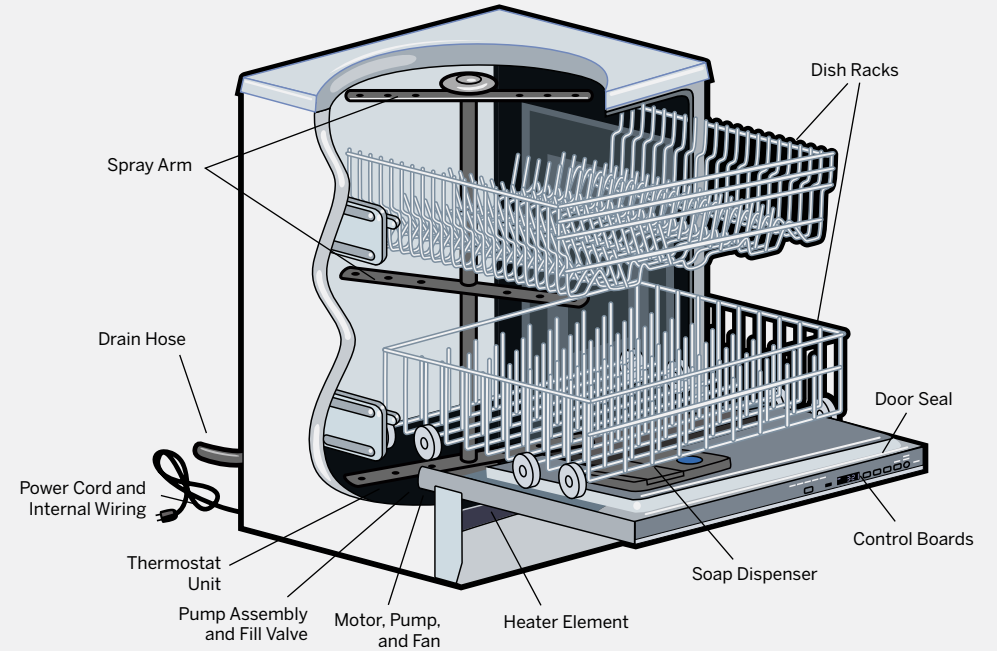

Generator FULL SERVICE

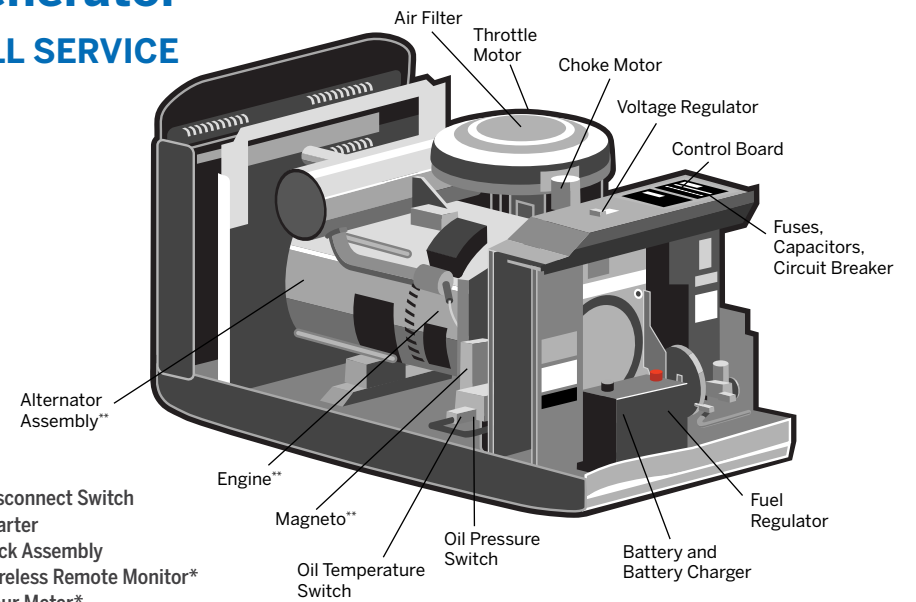

- Disconnect Switch
- Starter
- Lock Assembly
- Wireless Remote Monitor*
- Hour Meter*
- Transfer Switch
- Transformer and Relay

(Full Service Plan available on air-cooled generators up to 20KW only.)

*Covered if installed by Constellation Home.
**Covered only under manufacturer's warranty.

SERVICE PLAN TERMS AND CONDITIONS

1. This Brochure Terms and Conditions and the Contract Terms and Conditions constitute a single Contract for the services described herein. Additional terms and conditions constituting a part of the agreement are provided in the Contract Terms and Conditions itself.
2. Equipment and/or systems must meet code requirements and be in good working condition at the time service begins. Coverage is subject to begin 30 days from date of plan sale, according to the start date at enrollment.
3. Constellation Home reserves the right to inspect and approve any equipment or system before issuing a new service plan. Any inspections are performed at our regular schedule of charges.
4. Constellation Home shall not be required to provide repairs exceeding a cost to Constellation Home of \$2,000 per Contract year, unless a Water Line plan (up to \$3,000 per Contract year) or Sewer Line plan (up to \$4,000 per Contract year).
5. This service plan will cover the adjustment, repair or replacement of any fully functional part that fails through normal use, as specified in the brochure drawing(s) and detailed in the following:

GENERAL LIMITATIONS

- **Covered:** residential applications only; one system/appliance/equipment per plan as identified at the time of enrollment.
- **Not Covered:** normal routine maintenance (unless otherwise stated); any service work or replacement of parts caused by factory defects, pre-existing conditions, faulty system design or installation; service made necessary as a result of fire, theft, flood, acts of God, accidental damage, abuse, neglect, vandalism, unauthorized alterations or any other abnormal conditions; jacket trim or insulation; leveling legs; decorative parts, trim or finish; any associated masonry or drywall work.

APPLIANCES

- **Covered:** refrigerators; gas or electric ranges; gas or electric wall ovens; gas or electric cooktops; dishwashers; built-in microwaves; freezers; washers; gas or electric dryers.
- **Not Covered:** built-in connected, multimedia or appliance accessories; pedestal washers; heat pump dryers; multi-functional ranges; microwaves (unless built-in component of range or oven combinations); all-in-one washer/dryers; components of an appliance; filters; cabinet parts; light bulbs; accessories; drips pans; door liners; dishwasher air gap; utensil supports finish discoloration or touch-up.

COOLING/HEATING

- **Covered:** central air conditioners; heat pumps; forced warm air furnaces; hot water boilers; steam boilers; aquatherms; ductless air conditioner or heat pump systems.
- **Not Covered:** rooftop units; electric baseboard units; pumps and loops associated with earth-coupled or ground source heat pumps; electric radiant heating; oil-fired or oil-condensing units; combination solid fossil fuel units; commercial applications over 500,000 BTU/HR input; single heating systems that supply more than two heating zones or heating/cooling systems partially or completely powered by solar energy; windows air conditioners; refrigerant. Service to repair and/or replace heat exchangers; outside temperature sensors; jacket trim;

decorative parts; chimneys; registers; add-on power vents; vent connectors; air filters; fuel lines; fuel storage tanks; fuel shut-off valves; circuit breakers or exposed wiring; humidifiers and air cleaners (unless covered under a separate service plan); insulation; duct work; remote automatic water feed; boiler sections; solution pumps; internal or external domestic water heating coils and their associated parts; sealed systems; or any otherwise covered part which is inaccessible. Correction of any problem directly connected with the heating system itself, such as venting air at radiators; flow valves; balancing systems; surging steam systems or zone valves and zone controls; auto fill valves; flow checks; boiler feed pumps; or steam traps are not covered. Any water leaks caused by a clogged condensation or drain line. Any increase in utility bills resulting from use of emergency heat, or any energy-saving devices that are added onto the original heating/cooling systems, unless otherwise stated above.

ELECTRICAL

- **Covered:** exposed interior wiring; panels and sub-panels (repair only); breakers; fuses; receptacles; GFI receptacles; switches; bathroom built-in exhaust fans (repair only); ceiling fans (replacement will be like-for-like quality, coverage up to \$100 per fixture); exposed junction boxes; light fixture repair and replacement (fixture supplied by customer; must have identical mounting configuration; excludes chandeliers); outdoor motion-sensor lights; photocells on outdoor lights (no underground wiring).
- **Not Covered:** service entrance cables; fire or security alarms; intercoms; doorbells; timers; inadequate wiring capacity; power surge or failure; failure due to rodents or insects; non-approved wiring connections or junctions; low voltage wiring systems; landscape lighting; attic power ventilators; central vacuum systems; direct current (D.C.) wiring or components; garage door openers; improper size of panel (overloaded); local, state or federal code violation; power failure; light bulbs; touch pad assemblies; remote transmitters; knob and tube wiring.

GENERATOR

FULL-SERVICE PLANS

- **Covered:** transfer switch; disconnect switch; starter; oil pressure switch; oil temperature switch; control board; battery; battery charger; fuel regulator; voltage regulator; transformer; relay; fuses; capacitors; circuit breaker; throttle motor; choke motor; air filter; wireless remote monitor*; hour meter*; magneto**; alternator assembly**; engine**; lock assembly.
- **Not Covered:** portable generators; main circuit panel; circuits; appliances and/or any equipment connected to generator; load manager/shedding devices; gas piping (beyond generator gas shut off); any landscaping, boxes, or concrete pad at/around where the generator resides. Any increase in utility bills resulting from use of generator.

PREVENTIVE MAINTENANCE PLANS

- **Covered:** one or two annual maintenance checks per contract term (based on coverage selected at enrollment).
- **Not Covered:** labor and parts for repairs.

PLUMBING

- **Covered:** leaks or breaks in water, drain, gas, vent or waste lines (exposed only); toilet mechanisms; toilet wax ring seals; toilet flanges (excluding lead bends); angle stops (if present); main shut-off valves; hose bib shut-off valves

(if accessible); permanently installed interior sump pump (ground water only); drain cleaning (inside house); kitchen sink faucet repair and replacement (faucet supplied by customer; must have identical mounting configuration); garbage disposal repair and replacement (disposal supplied by customer).

- **Not Covered:** bathtubs or showers; leaks or breaks in lines caused by freezing; fixtures, faucet replacement (except kitchen sink), faucet repair (except kitchen sink); shower or tub valves; shower and tub drains; shower enclosures and base pans; caulking; grouting; septic tanks; pressure regulators; water purifiers; water softeners; toilet seat; inadequate water pressure supply; sauna and steam rooms; leaks or breaks caused by foundation movement; water storage tanks; dryer vents; all stoppages in vent and drain lines on outside of house; water heaters; boilers.

SEWER LINE

- **Covered:** repair or replacement of the primary outside sewer line that is impeded due to normal wear and tear, tree roots or structural failure. Coverage begins at the point of public/septic tank waste connection to the point of entry of your home. Replacement shall be at the sole discretion of Constellation Home.
- **Not Covered:** any shared sewer line that supplies service to multiple residences; public sanitation system or septic system; any primary sewer line that is greater than six inches in diameter; any storm sewer lines; sump, trash, grinder or lift pumps.

WATER HEATER

Covered: gas or electric water heaters; power vented water heaters; tankless water heaters; heat pump water heaters

Not Covered: water heater tank failure; water heating systems partially or completely powered by solar energy; expansion tank; thermal expansion devices for water heaters; catalytic surfaces; heat exchanger; combustion shut-off system; vent connectors; water piping.

WATER LINE

- **Covered:** repair or replacement of the primary outside water line that has the flow of water interrupted due to normal wear and tear, leaking or structural failure. Coverage begins at the point of public/well system connection to the point of entry of your home (water meter or main water shut-off valve). Replacement shall be at the sole discretion of Constellation Home.
- **Not Covered:** any shared water line that supplies service to multiple residences; branch lines that supply secondary buildings; outdoor water systems (ex. sprinkler systems, pools, hot tubs, etc.); any repair or replacement of components associated with the water utility system (ex. meters, curb valves, etc.); well pump system (including the pitless adapter).

WATER PRODUCTS

- **Covered:** control valve (repair only); control switch; bypass valve; drain valve; drain line; brine line tubing; safety float; gauge; relief valve; check valve. Water Neutralizer Plan includes one annual maintenance check (plan shall cover the service with 1 NE 75 cu neutralizer material per year).
- **Not Covered:** carbon tanks; constant pressure well systems; media tanks; tank-tee filter media inside tank (unless otherwise stated); replacement of control valves; replacement of main tank or brine tank.

WELL PUMP SYSTEM

- **Covered:** well pump (up to \$1,200 per contract term); drain valve (inside home only); brass nipple; relief valve (inside home only); pressure gauge; pressure switch; start control box; pump protector; ball valve.
- **Not Covered:** well pumps over 10 years old; above/underground piping; cables; ropes and/or electrical lines leading to or away from the pump (including inside of well casing); well casings; storage, holding or pressure tanks; secondary or booster pumps; redrilling of wells; any components (including well pumps) of geothermal and/or water source heat pumps regardless of location or relationship to covered parts.

*Covered if installed by Constellation Home **Covered only under manufacturer's warranty.

6. **If the component of the equipment/system covered by this Contract is not repairable due to its general condition, or due to the inability of the manufacturer to provide suitable parts, Constellation Home shall have no liability. If service has been rendered, no refunds will be given.** Replacement parts may not be available for products greater than ten years old. Constellation Home reserves the right to restrict specific makes of equipment from eligibility due to non-availability of parts, and the choice of parts to be used shall be at the discretion of Constellation Home. Constellation Home will put forth its best effort to provide replacement parts, components or systems of similar mechanical capabilities of the original (where available). However, Constellation Home is not liable to provide exact match in color, type or brand. Constellation Home is under no obligation to upgrade or make modifications to the original system, components or items covered by this Contract.
7. All replacement parts must be supplied by Constellation Home. On an exception basis only (in accordance with Customer's service plan), Constellation Home may use customer-supplied fixtures or devices, and will warrant the installation work, but does not warrant the customer-supplied fixture or device. For any non-covered repairs, customers shall receive a maximum discount of 15% to be applied against Constellation Home's standard repair charges.
8. For Plumbing and Electrical Plans Only, in the event of a breakdown covered in this Contract, you shall be required to pay a \$50 per call, per item deductible. A deductible payment is required for each claim of an individual breakdown covered under this service agreement. The Smart Service 10% discount for plumbing and electrical service does not apply to the \$50 deductible.
9. If an additional service technician, electrician or plumber must be called for assistance on a service call (i.e. to remove a unit for service), the customer may be charged for the additional labor. The customer will be notified prior to any such charges being incurred.
10. All service will be performed during regular business hours, within our service territory. All repairs must be performed by Constellation Home technicians, electricians and plumbers. Annual tune-ups/inspections are scheduled at the Customer's request, during normal business hours between 7:30 a.m. and 5:00 p.m., Monday through Saturday.
11. Customer must provide Constellation Home with safe access to and safe working conditions at and around covered products. Service work will be performed when weather conditions permit safe access, when applicable.
12. To obtain service under this Contract, or if you have any questions, call 888-243-4663. For billing inquiries, call between 9:00 a.m. and 4:30 p.m., Monday through Friday.

Home Service Plans



Constellation Home[®]

Formerly **BGE HOME**

888-243-HOME
ConstellationHome.com

BGE HOME is not the same company as BGE, a regulated utility.

MD HVAC #10605, MD Master Electrician #12501, MD Master Plumber/Gas Fitter #89794, Balto. Co.
Master Plumber/Gas Fitter #MP-11256, WSSC #72758, MHIC #2273

© 2022 Constellation Home

04/22 MD_SSSP