

### ELECTRIC WATER HEATER

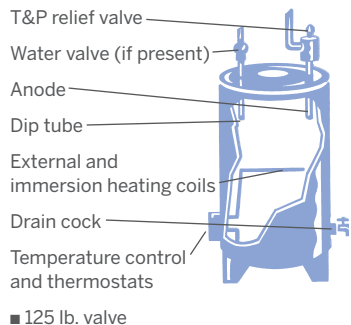

### MARATHON ELECTRIC WATER HEATER

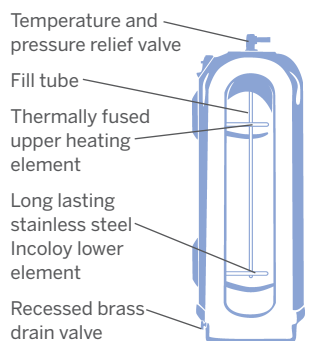

### POWER VENTED GAS WATER HEATER

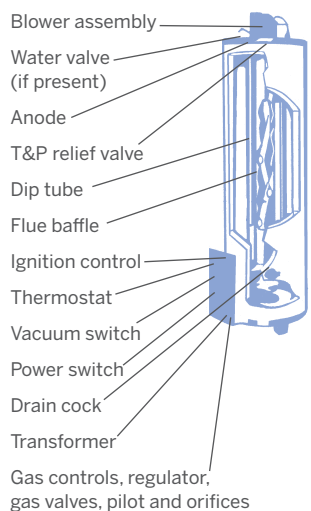

Water heater tank failure is not covered.

### TANKLESS WATER HEATER

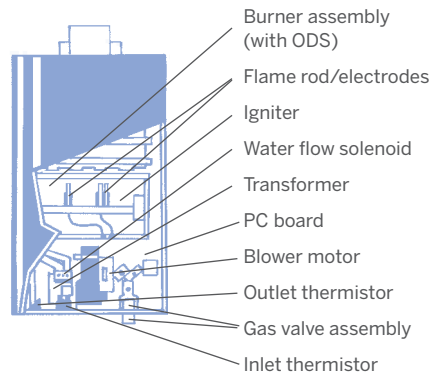

Coverage excludes heat exchanger and heat exchanger thermistor.

### HEAT PUMP WATER HEATER

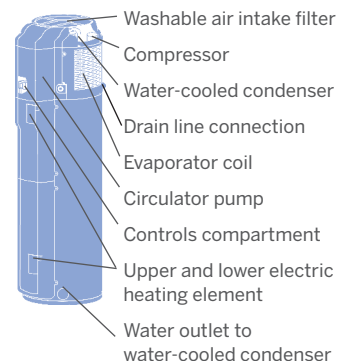

### OIL-FIRED WATER HEATER

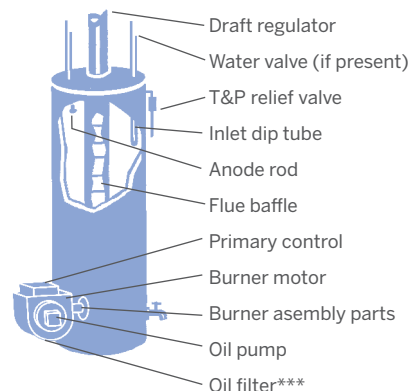

Coverage includes one annual inspection of your water heating system.

### GAS WATER HEATER (FVIR)

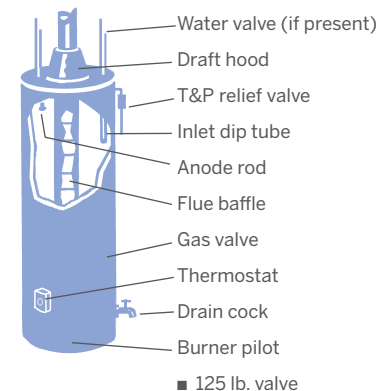

### GAS WATER HEATER

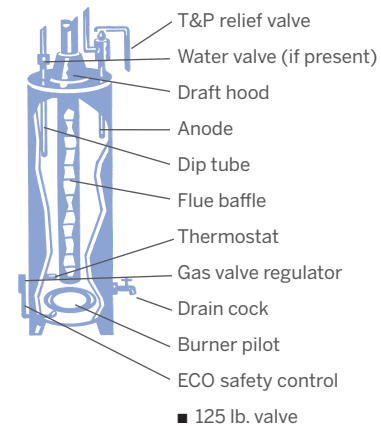

### General Terms For Service Plans On Home Comfort Equipment

- This service Contract (Contract) will cover the adjustment of the heating/cooling system, water heater or the replacement of any functional part as specified in this brochure. This brochure and the accompanying Contract constitute a single Contract for the services described herein. Additional terms and conditions constituting a part of the agreement are provided only in the Contract itself. Normal routine maintenance is not included and not provided. This Service Plan covers one System per Contract.
- Service made necessary as a result of fire, theft, floods, acts of God, accidental damage, abuse, neglect, vandalism, unauthorized alterations or any other abnormal conditions are not covered by this Contract. Consequential or other damages resulting from the failure of the system or any part or parts are not included. Systems with pre-existing conditions, faulty design or installation will not be covered.
- This Contract shall cover the adjustment, repair or replacement of the following functional parts that fail through normal use: thermostats (excluding batteries and programmable thermostats—except those installed by Constellation Home), transformers, two-speed relays, electric heating elements, sequencers, electronic ignition systems (either part of the original furnace or added to the furnace), switches directly associated with the unit, blower motors, fans including bearings and housing supports, belts, pulleys, aquastats, gauges, steam pressure controls, gauge glasses including tricocks (for gas-designed boilers only), circulator motors and couplings, circulator pump, low water cutoff, automatic feeds (on steam boilers only), expansion tank (drainage only), and multiple pumps and/or zones in existing dwelling for hot water boilers. It shall also cover controls relating to the operation of the burner, such as gas valves, main burners (subject to availability), and heating unit manifolds. Coverage for oil-fired equipment includes the burner assembly parts (as well as electrodes, nozzle adapter, CAD cell and porcelain insulators), oil pump (plus gasket and strainer), oil filter, burner motor and primary control.
- This Contract shall not cover:
  - The Contract does not cover air filters, cabinet parts, decorative trim, accessories, drip pans, leveling legs, catalytic surfaces, finish discoloration, touch up, and any associated masonry work or drywall work.
  - Roof top units, electric baseboard units, air conditioners or heat pumps connected to earth-coupled or ground source heat pumps, electric radiant heating, oil condensing units, combination solid fossil fuel units, commercial applications over 500,000 BTU/HR input, single heating systems that supply multiple heating zones (except hot water systems), heating/cooling systems partially or completely powered by solar energy, water heater tanks and water heating systems partially or completely powered by solar energy.
  - Service to repair and/or replace heat exchangers, combustion chambers, burner assembly replacements, outside temperature sensors, jacket trim, decorative parts, chimneys, registers, add-on power vents, vent connectors, air filters, fuel lines, fuel storage tanks, fuel shutoff valves, circuit breakers or exposed wiring, humidifiers and air cleaners (unless covered under a separate service plan).

insulation, duct work, remote automatic water feed, boiler sections, solution pumps, internal or external domestic water heating coils and their associated parts, or any otherwise covered part which is inaccessible.

- Any service work or replacement of parts caused by faulty system design or installation, or the correction of any problem directly connected with the heating system itself such as venting air at radiators, expansion tank problems, flow valves, balancing systems, surging steam systems or zone valves and zone controls, thermal expansion devices for water heaters, leaking pump seals, auto fill valves, flow checks, boiler feed pumps or steam traps.
- Any environmental damage or contamination caused by improper maintenance, a defective system or leakage/spillage of fuels (oil, propane or natural gas) from a storage tank, fuel pipe or any part of the system and/or appliance.
- Routine maintenance such as oiling, inspections (except where otherwise specified), seasonal turn-ons/turn-offs or cleaning of filters, ducts, and chimneys (excluding base).
- Any energy saving devices that are added onto the original heating/cooling systems unless otherwise stated above.
- Attic units without appropriate flooring or access.
- Repair or replacement of parts involving friable asbestos.
- Any increase in utility bills resulting from use of emergency heat is not covered under this contract.

5. If a gas, electric or oil heating/cooling system or water heater is not repairable due to its general condition, or due to the inability of the manufacturer to provide suitable parts, Constellation Home shall have no liability other than to return a prorated portion of the price of the service contract, based on the full months remaining in the contract. If service has been rendered, no refunds will be given.

6. Where offered, maintenance checks will be performed once a year. Maintenance checks (inspections) are scheduled at the customer's request.

7. Constellation Home reserves the right to inspect and approve any equipment before issuing a new service plan (heat pumps and central air conditioners must be inspected before coverage can occur). We will waive this inspection if the equipment is currently under manufacturer's warranty or if this plan is a continuation of an existing plan issued by Constellation Home. Any necessary inspections will be performed at our regular schedule of charges.

8. Service work on the outside unit of a heat pump or central air conditioning system will be performed when weather conditions permit safe access.

9. If an additional service technician must be called for assistance on a service call, (i.e. to remove a unit for service) the customer may be charged for the additional labor.

10. All replacement parts must be supplied by Constellation Home. Customer supplied parts will not be used.

11. For billing inquiries, contact us at 1-844-307-HOME, Monday–Friday, 9 a.m.–4:30 p.m.

**Service Plans**  
**1-844-307-HOME**  
**constellationhome.com**



## Service Plans

Home Heating and  
Air Conditioning Systems  
Water Heaters  
Humidifiers and Air Cleaners

BGE Home Products & Services, LLC is doing business as Constellation Home. BGE HOME is not the same company as BGE, a regulated utility.

MD HVAC #01-7302  
MD Master Electrician #7070  
MD Master Plumber/Gas Fitter #02-6739  
HIC #PA106613  
Master Plumber #1005  
Master Electrician #918



# Protect Yourself With A Service Plan From Constellation Home For Reliable, Economical Repair Coverage.

Even the best equipment needs occasional service. That's why it pays to be prepared, especially for necessities like heating, air conditioning, and hot water. A service plan from Constellation Home saves you time, money and worry. We'll repair or replace covered parts that fail through normal use, and help keep your equipment in peak condition for a longer service life. A typical repair on a home heating or air conditioning system can be two to three times the cost of our service plan. Our annual service plan covers these repairs for you.

## Peace-of-Mind Coverage

Our service plans provide worry-free protection with these benefits for you:

- No charge for labor or covered parts
- Local, licensed technicians and plumbers
- Unlimited service calls
- Priority service
- Large parts inventory
- One annual maintenance check for central air conditioners and heat pumps

## Our Service Plans Take the Heat for Replacing These Parts

### STEAM GAS HEAT SYSTEM

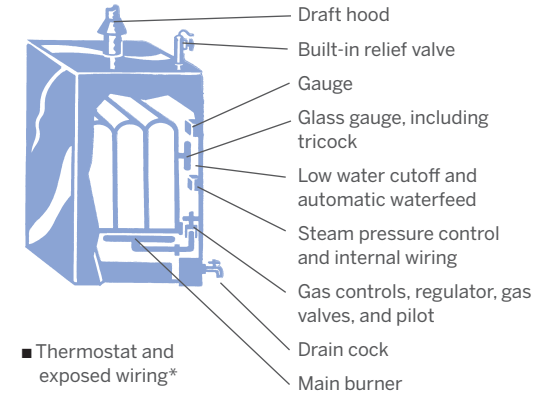

### HOT WATER GAS HEAT SYSTEM

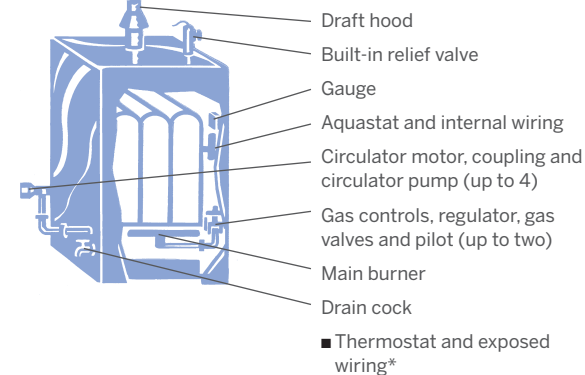

*(Water leaks at the circulator flanges or piping are not covered)*

### HEATING AND AIR CONDITIONING ACCESSORY ITEMS

#### ELECTRONIC AIR CLEANER

- All functional parts

Coverage is available only in conjunction with heating or cooling system policy.

#### WHOLE HOUSE HUMIDIFIER

- All functional parts

### CENTRAL AIR CONDITIONING UNIT

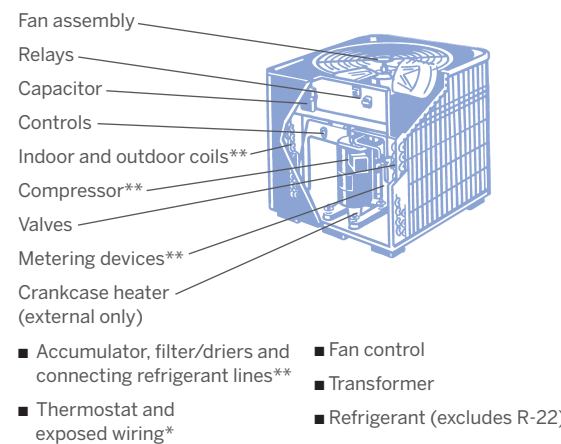

*Coverage includes one annual inspection of your cooling system.*

### HEAT PUMP (OUTDOOR UNIT)

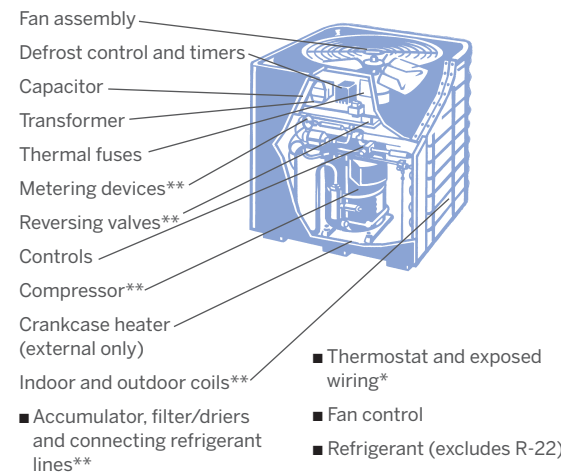

*Coverage includes one annual inspection of your heating or cooling system.*

\*Coverage excludes digital thermostat unless installed by Constellation Home.  
 \*\*Covered only under manufacturer's warranty.  
 \*\*\*Covers standard cartridge type oil filters.

### FORCED WARM AIR GAS HEAT SYSTEM

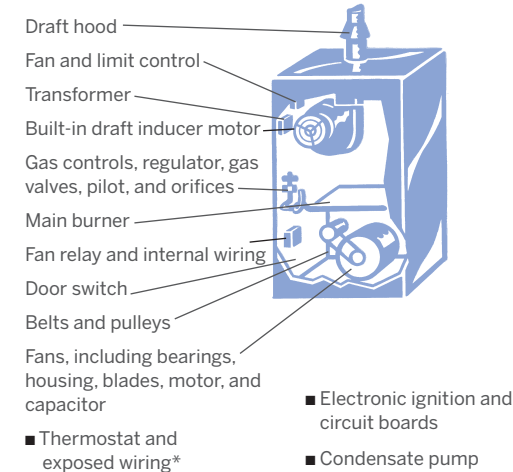

### HIGH-EFFICIENCY FORCED WARM AIR GAS HEAT SYSTEM

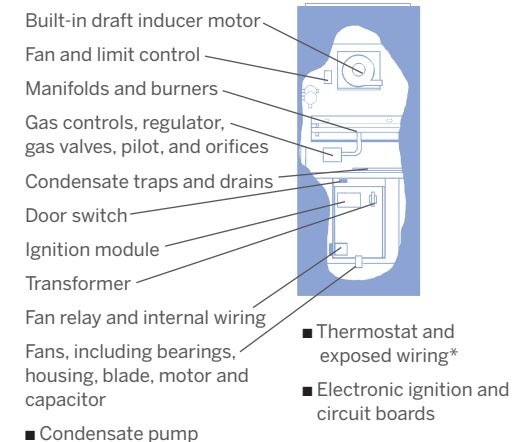

### ELECTRIC HEAT SYSTEM

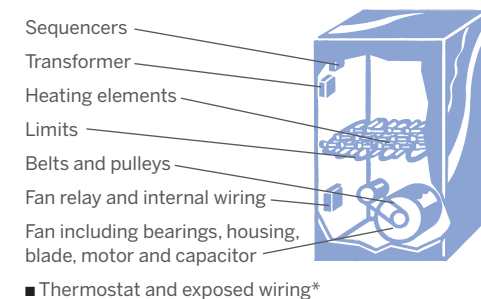

### FORCED WARM AIR OIL-FIRED HEAT SYSTEM

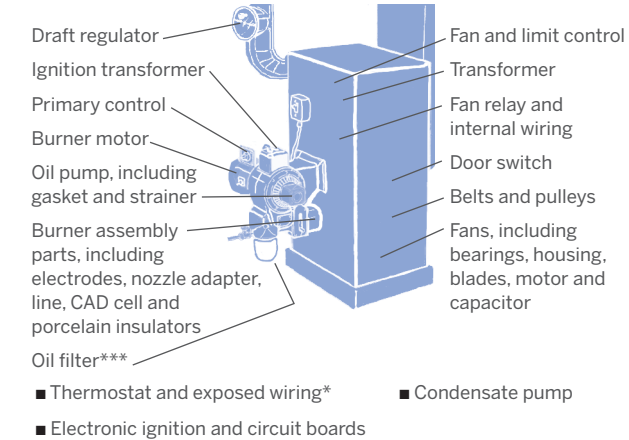

*Coverage includes one annual inspection of your heating system.*

### STEAM OIL-FIRED HEAT SYSTEM

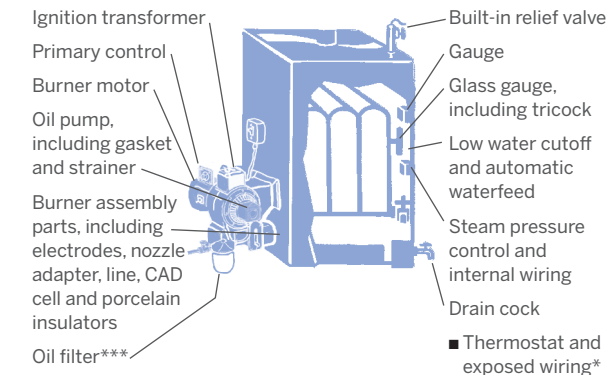

*Coverage includes one annual inspection of your heating system.*

### HOT WATER OIL-FIRED HEAT SYSTEM

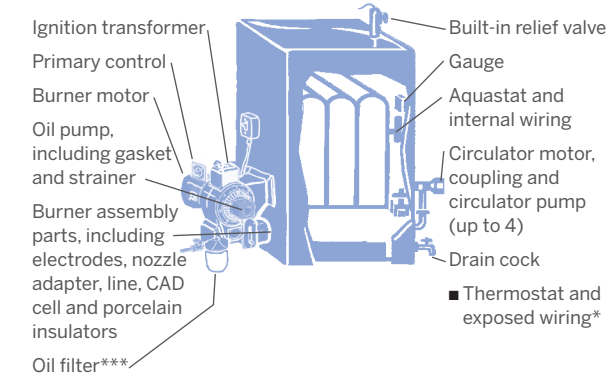

*Coverage includes one annual inspection of your heating system. (Water leaks at the circulator flanges or piping are not covered)*

## Our Reputation is Superior Service

BGE HOME has been providing heating, cooling and plumbing services in Maryland for decades. We take pride in our satisfaction rating of over 95% and that 9 out of 10 of our customers would refer us to their family and friends. And, on average, our technicians and plumbers have more than 11 years of experience. We are bringing that level of customer commitment to your area with our Constellation Home division.

At Constellation Home, we stand for quality, reliability and convenience. We offer service on ALL major brands of heating and cooling systems, as well as provide a complete line of plumbing services. Our team of licensed, professional technicians and plumbers provides incomparable personal service—before, during and long after the sale.

## Convenient, Continuous Protection

Single year service plans for gas, electric and oil water heaters and heating and air conditioning systems are available regardless of where your equipment was purchased. An inspection may be required before a new service plan is issued.

Your economical service coverage can be easily extended year after year with our convenient automatic renewal feature. Prior to the expiration of your service plan, you will receive a notice to confirm that your plan is being renewed for another year and to inform you of your option to cancel at that time.

## Apply Today

Why wait? Sign up for a service plan from Constellation Home today and enjoy the reliable, high-quality service thousands of people count on every day.

**CALL US TODAY!**

**1-844-307-HOME**  
**constellationhome.com**